



DBPY-15W-12V



Available Models¹

- DBPY-15W-12V
- DBPY-15W-24V

Part Number Breakdown

Example: DBPY-15W-12V

Series	Output Power	Output Voltage
DBPY [DiodeDrive, Board Mount, Enclosed, Plastic]	15W [15W]	12V [12 VDC] or 24V [24 VDC]

Overview

The DiodeDrive AC to DC encapsulated power supply has pin connections for PCB mounting with a direct soldered connection, delivering integrated low-voltage power into compact systems without external low-voltage wiring. The circuit board mounting reliably delivers a constant voltage and current output to power smaller system components. Built-in safeguards ensure dependable operation, including short circuit, surge, overvoltage, and overload protections. The low-profile design and efficient power output are ideal for limited-space installations.

Features

- Low-profile board mount for limited-space installations
- Class II double insulated for improved safety
- Pin connections to solder directly to PCBs for integrated designs
- Protections: short circuits, overload, overvoltage, and 2G vibration

Product Details

- Black polycarbonate housing
- Input pins: 1mm
- Output pins: 1mm
- Suitable for dry locations
- 100-240 VAC input

Certifications and Compliances

- UL Recognized - UL 8750, UL 879
- CE compliant



Applications

- Industrial Automation
- Industrial Equipment
- Industrial Facilities
- OEM Components

Warranty

- 3-year warranty





DBPY Series

Constant Voltage Power Supply Specifications

SPECIFICATIONS	DBPY-15W-12V	DBPY-15W-24V
OUTPUT		
Output Power	15W	15.12W
Output Voltage (±2.5%)	12 VDC	24 VDC
Output Current	1.25A	0.63A
Ripple and Noise (max)	200mVp-p	
Line Regulation	±0.3%	
Load Regulation	±0.5%	
Setup, Rise Time (full load)	1800ms, 30ms @ 115 VAC; 1000ms, 30ms @ 230 VAC	
Hold Up Time (TYP, full load)	10ms @ 115 VAC; 40ms @ 230 VAC	
INPUT		
Input Voltage (rated)	100-240 VAC	
Input Voltage (NOM)	90-264 VAC	
Input Frequency	50/60Hz	
No Load Power Consumption	0.1W max.	
Input Current (TYP)	700mA @ 115 VAC; 300mA @ 230 VAC	
Inrush Current (cold start)	20A @ 115 VAC; 45A @ 230 VAC	
Leakage Current	< 0.707mA/264 VAC, 50Hz	
Efficiency (TYP)	82%	83%
Capacitive Load (max)	2000uF	580uF
ENVIRONMENTAL		
IP Rating	IP20	
Environmental Rating	Non-weatherproof, Suitable for Dry Locations	
Operating Temp., Humidity	-30 to 85°C (-22 to 185°F); 20-90% RH, non-condensing (see 'Derating Curves')	
Storage Temp., Humidity	-40 to 85°C (-40 to 185°F); 10-95% RH, non-condensing	
Temp. Coefficient	± 0.03%/°C (0 to 50°C)	
Vibration	10-500Hz, 2G 10min. /1 cycle, period for 60min. each along X, Y, Z axes	
SAFETY		
Withstand Voltage	I/P-O/P: 3k VAC/1 minute	
Isolation Resistance	I/P-O/P: 100M Ohms/500VDC/25°C 70% RH	
PROTECTIONS		
Short Circuit	Hiccup mode, recovers automatically after fault condition is removed	
Overload	115%-190% Rated Output current Hiccup mode, recovers automatically after current goes down	
Overvoltage	12.6-16.5V	25.2-34V
	Hiccup mode, recovers automatically after fault condition is removed	
MECHANICAL		
Material	Black flame retardant and heat resistant plastic	
Cooling Method	Natural air convection	
Connection Type	PCB Terminal Pins	
MTBF	>900K hours min. 25°C [MIL-HDBK-217F]	



T 866.201.2238
 F 314.972.6202
 www.diode-drive.com
 email: commercialsales@diode-drive.com

Rev V1.3 Date: 06/24/2025
 Specifications are subject to change without notice.

EMC			
EMC EMISSION	Parameter	Standard	Test Level/Note
	Conducted	BS EN/EN55032 (CISPR32)	CLASS B
	Radiated	BS EN/EN55032 (CISPR32)	CLASS B
	Harmonic Current (Note 7)	BS EN/EN61000-3-2	CLASS A
	Voltage Flicker	BS EN/EN61000-3-3	-
EMC IMMUNITY	BS EN/EN55035, BS EN/EN61000-6-2		
	Parameter	Standard	Test Level/Note
	ESD	BS EN/EN61000-4-2	Level 3, 8KV air; Level 2, 4KV contact, criteria A
	Radiated Susceptibility	BS EN/EN61000-4-3	Level 3, criteria A
	EFT/Burest	BS EN/EN61000-4-4	Level 3, criteria A
	Surge	BS EN/EN61000-4-5	Level 4, 2KV/L-N, criteria A
	Conducted	BS EN/EN61000-4-6	Level 3, criteria A
	Magnetic Field	BS EN/EN61000-4-8	Level 4, criteria A
	Voltage Dips and interruptions	BS EN/EN61000-4-11	>95% dip 0.5 periods, 30% dip 25 periods, >95% interruptions 250 periods

SPECIFICATION NOTES:

1. All parameters NOT specially mentioned are measured at 230 VAC input, rated load, and 25°C of ambient temperature.
2. Ripple and noise are measured at 20MHz using a 12" twisted wire-pair terminated with a 0.1µF and 47µF parallel capacitor.
3. Tolerance: includes set up tolerance, line regulation, and load regulation.
4. Application Altitude: 2000m
5. Full load can be operated at -30°C to 50°C. Load should be reduced at 50°C to 85°C. Refer to "Output Derating Curves."
6. Ambient temperature derating of 3.5°C /1000m with fanless models for operating altitudes higher than 2000m (6500ft).
7. The power supply is considered as an independent unit. Systems with the power supply as a component require re-confirming that the system complies with the EMC directives.
8. Soldering Temperature | Wave soldering: 265°C, 5s (max.); Manual soldering: 390°, 3s (max.)

Functional Diagram

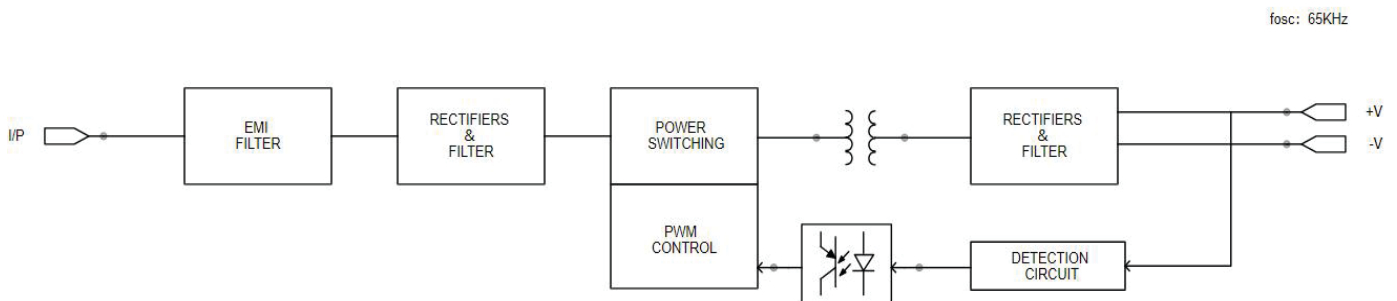

DBPY Series

Constant Voltage Power Supply Specifications

Derating Curves

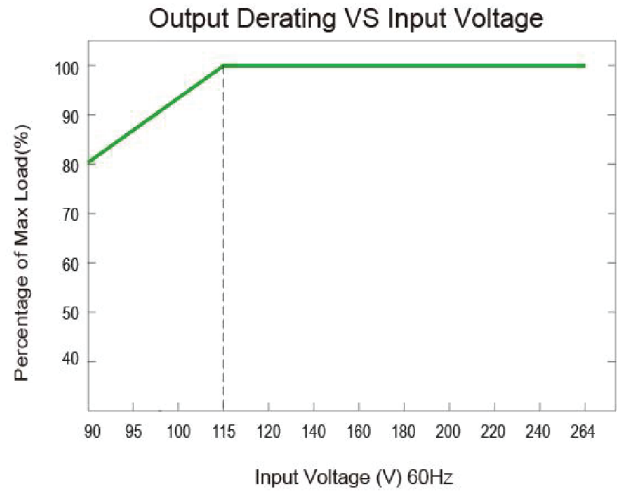
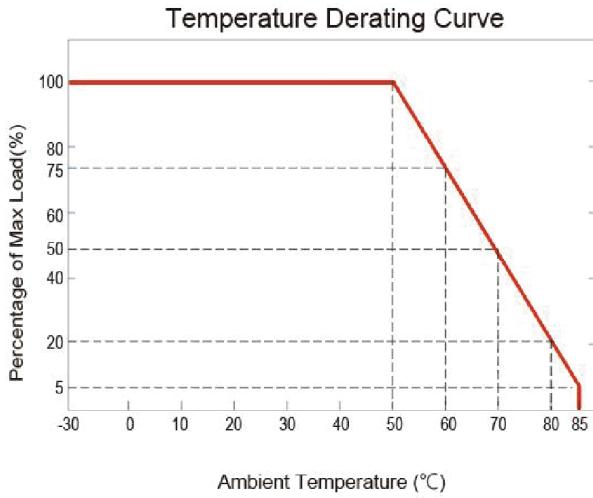

Dimensional Drawings

